



F2N-60

Tapping Unit

■ Specification

Tapping Capacity	M6(mild steel)
Chuck Capacity	ER16~ ϕ 10, JT1- ϕ 6.5
Stroke	60mm
Thread Pitch	0.25mm~1.25mm
Weight	20kg
Gauge Lubrication	Grease
Transmission	V-belt, H.T.D.-5GT
Max. RPM	1,800rpm
Power	0.37kw-2P or 4P, 220V,380V

■ Consumption Parts

Spindle Bearing	NAX-1725Zx2
Pulley Bearing	6003ZZx1, 6203ZZx1
O-Ring	DKB-40.52.6x1, MB2215DUx1

- The unit is equipped with high precision, ground master gauge for precision and fine tapping works.
- Thread pitch should be given when ordering.
- Master gauge is mounted internally to the unit body for application of less model change.
- Torque protection device is included for reducing tap breakage.
- Motor and pulley set can be mounted around the circle with interval of 45 degrees.





F2N-60

Tapping Unit

■ Dimensions

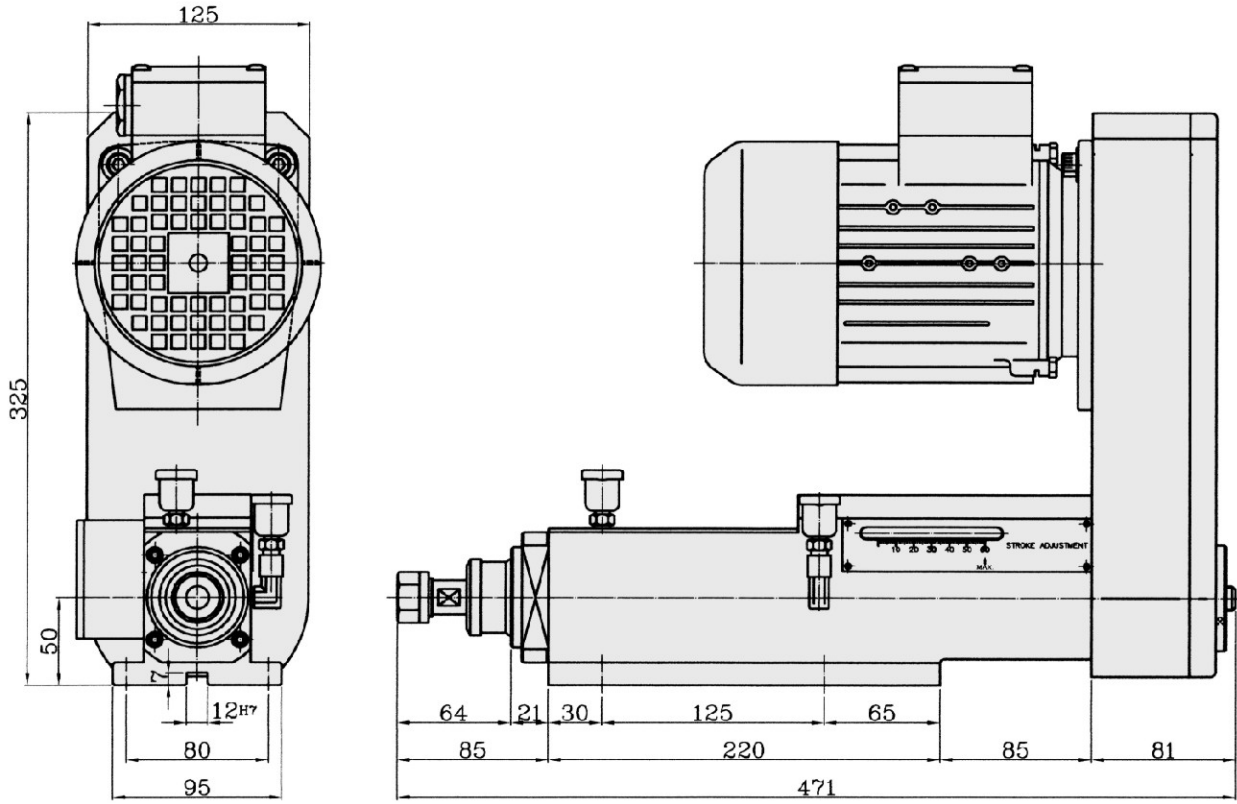

F2N-60-ER16

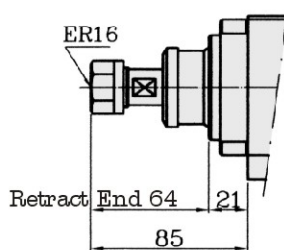

F2N-60-JT1

